

文

究院

学 术 研 究

2019

# 目录



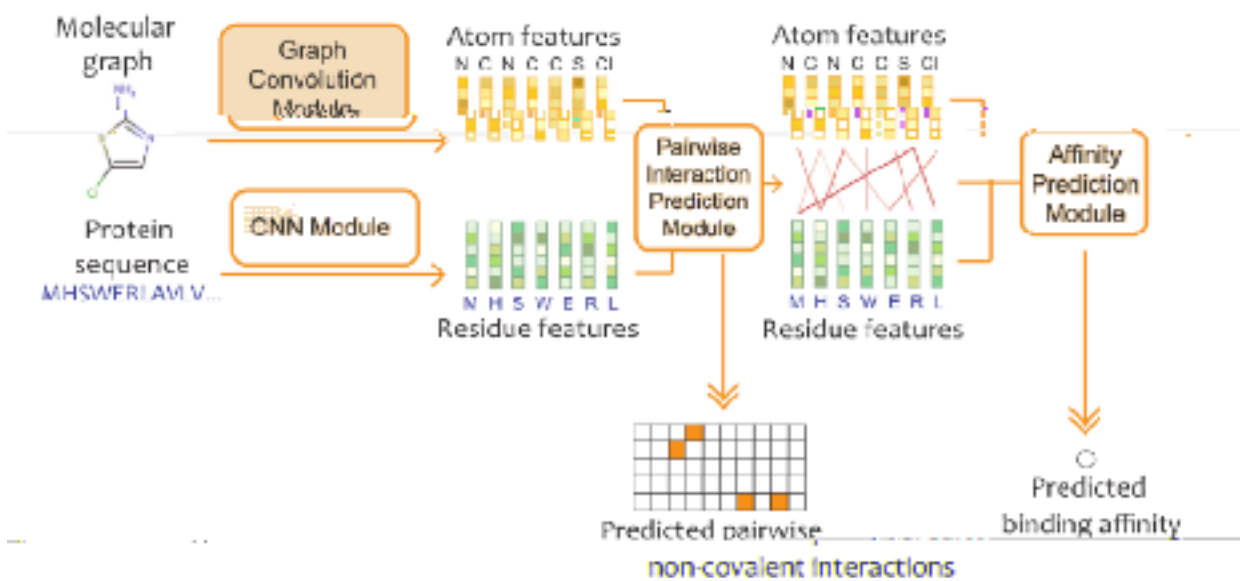



FY@

6UhgGUW]lm

G @8

Cfl #

bL ; b

f7@8L

@[!GcVc`Yj

??H

`&

7@8

Cfl#bL

>]Ub`@zLi UbrnUb`@ cZA ]b[ XU

? U]Zb[ ` @niž>]Ub`@""; fUX]Ybhi E ]Uc""Cb; YbYU]nU]cb`9ffcf`6ci bXg`cZB c]grn fUX]Ybhi

8 YgWbhiA U ]a ]nYg`h\YA Uf[ ]b`cZ< ca c[ YbYci g`B Yi fU` A YhcXg`Zcf`Bcb!7cbj Yi @Ufb]b[ ~ =7@F`&&&"

B Ykcf\_g` =7@F`&&&"







9F@5A

5HF]

(

; i Ub[1]Ub[ 'N\i žN]Wi Ub'@]ž

; i Ub[k Yb'MUb[ž7\cb[ 'Y'N\Ub[" 9d]gX]WFY]bZcfWa Ybh

9F@5A

@YUfb]b[ 'k]h '5ggV]U]j YA Ya cfm =7@F '8&8&'

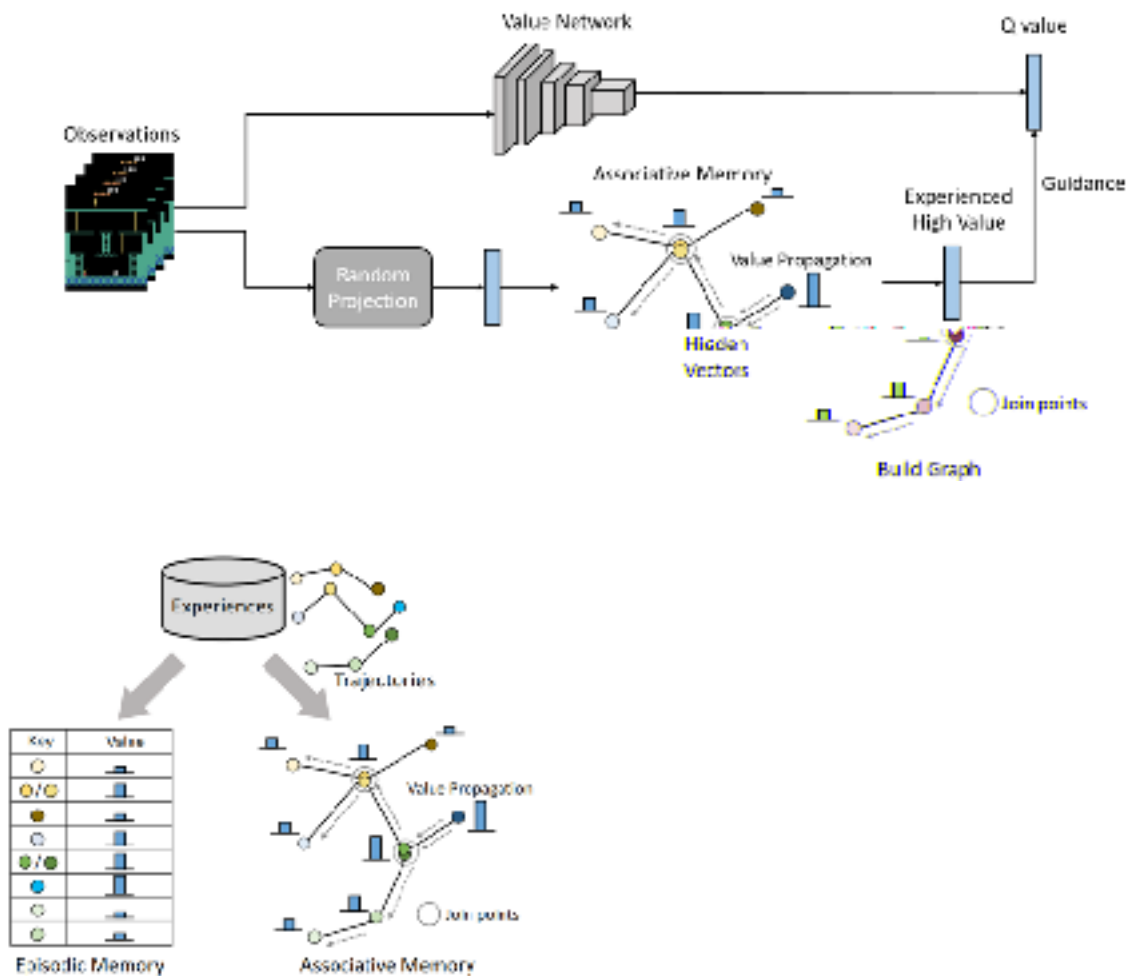



&GUF7fUZi=L

, S

Hcb[\Ub`K Ub[ž>]Ub\Uc`K Ub[ž

7\cb[m]`N\Yb[ž7\cb[†Y`N\Ub[" @YUfb]b[`B YUf`m

B8E

8 Ywa dcgUVYJ Ui Y: i bWjcbgj ]U`7ca a i b]Wh]cb`

A ]b]a ]rU]cb =7@F`&&&S"

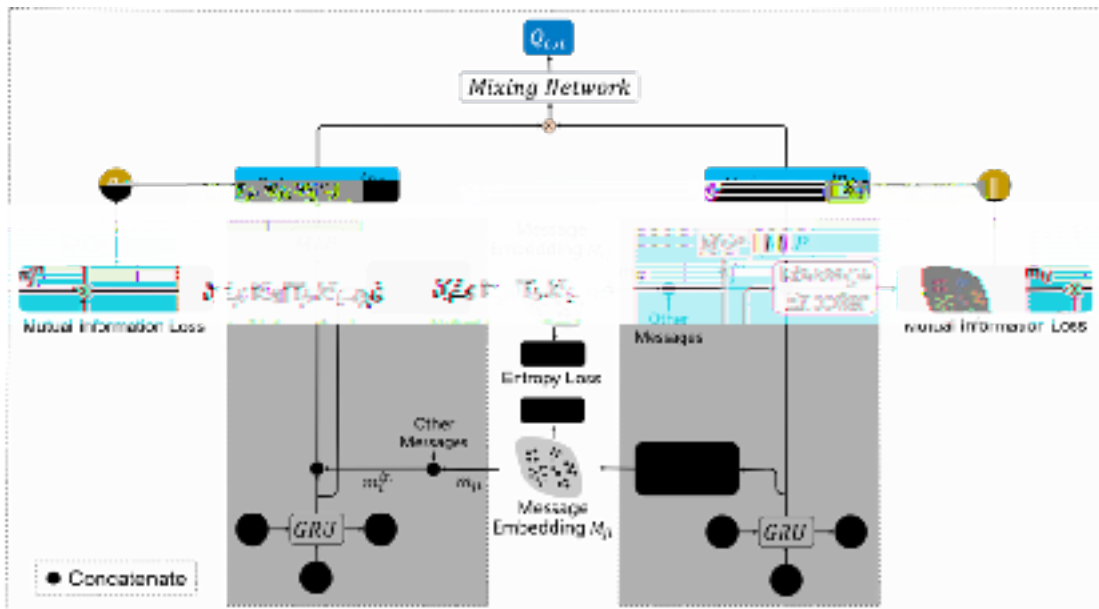

%

9H= 98H=

!

&

.....

Hcb[\Ub`K Ub[ž>]Ub\Uc`K Ub[ž

9H= 98H=

M]`K i ž7\cb[ ^Y`N\Ub[ " =bZi YbW!6UgYXA i `h]!5[ Ybh

9l d`cfU]cb =7@F`&&&"

!

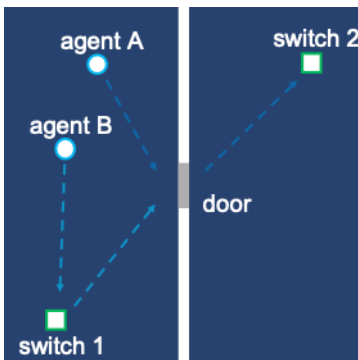

%

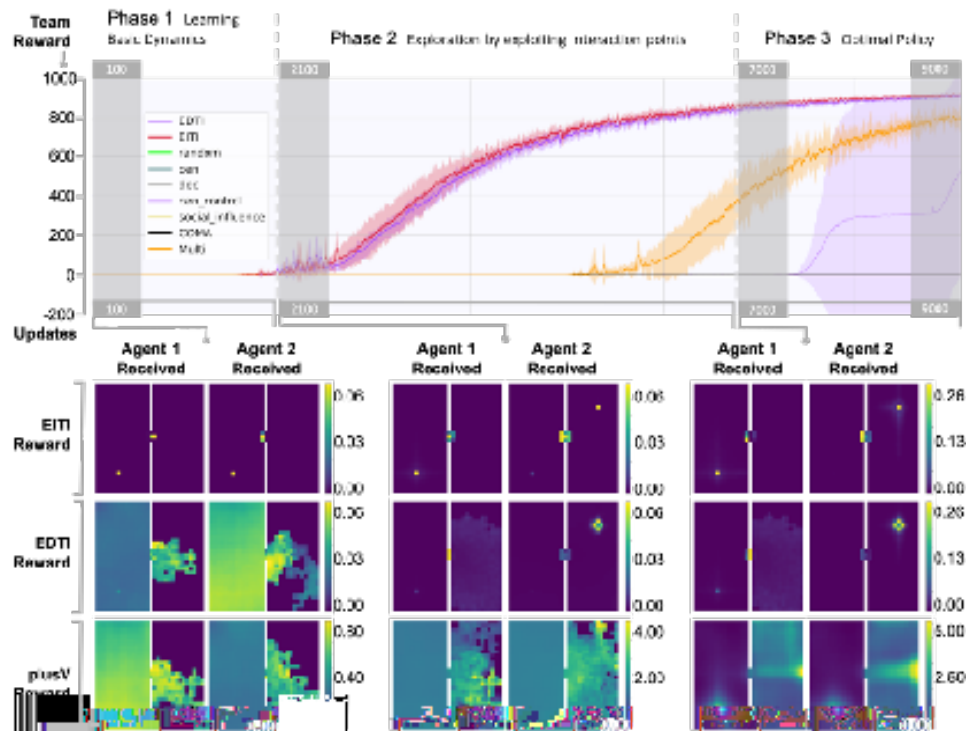

& - SSS

9H= 98H=



A=@ 75A9@

75A9@MCB%

)SSA6

75A9@

& 6

.....

Li ž; "žGcb[žN"žG bžN"ž? i ž7"ž

Mb[žN"ž@i ž7"žK Ub[žGžLi žK ""~75A9@:5 K YU`m

G dYfj ]gYX@Yfb]b[ : fUa Ykcf\_`Zcf< |gřcdUhc`c[ m=a UY

Gy[a YbHqcb` =77J `&S%"

75A9@

a i ħdY]bgLbW`Yfb]b[ž



.....

.....

~|Uc'G bzMjb'@z7\Uf'Ym7\Ybz~|\UY

@YYZL]b'@ji zN\cb[ d]b[ 'N\Ub[ z@b[ '< i Ub[ z@Y]G\ 'UbXK Y'

Li " : 8< YdYf.'5gg]ghI bg dYf] jgXX: fU X8 YfYm]cb'9l dYf]g'

k ]h' =bhYfUMj Y: YUhi fY'GYm]cb 'UbX'9j U'i U]cb 7< =

&&&&"



Df]bVdU!5[ YbhHAYcfm

A YWUblgā '8 Ygl[ b

Df]bVdU

BD

5[ Ybh

'C flc[ 'bE

7cbhfUM

'A Yb[ 'b[ '7\YbzD]b[ n\cb[ 'HUb[ ž

N)\YK Ub[ žG\Yb\_YL]UčžL]k Ub[ 'Mb[ "' C dhā U'7ca a cb'

7cbhfUMk ]h < Yhfcl YbYci g5[ Yblg 555=888"



; cc|`Y :UWcc\_

&S%

·G`YbžK Y|fUž6|b|\i`DYb|ž  
 < UbDYb|`@|i žA |WUY`N\Ub|žFi c\Ub`E |UbžMLb`< cb|ž  
 N\|; i cžNcb|nč`8 |b|žDYb|†b`@ žUbXD|b|nčb|`HUb|"  
 `FY|bZcfWa Ybha YWUb|ga `XYg| bžk |h`Udd`|W|qcbg`hc`  
 XhbUa |Wdf|Wb|`|b`g|cbg|fYXg|UFW`U W|cbg` 555=&S&S'

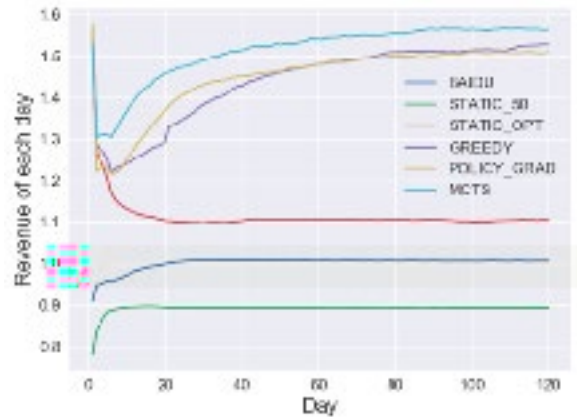
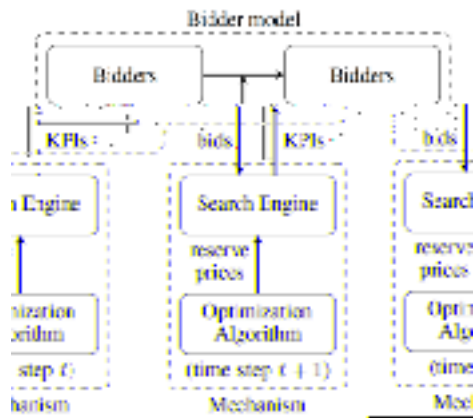

7\U    00  
 fl    %    L  
 00    &

fbYg\ch`cUXYWa dclhcbL

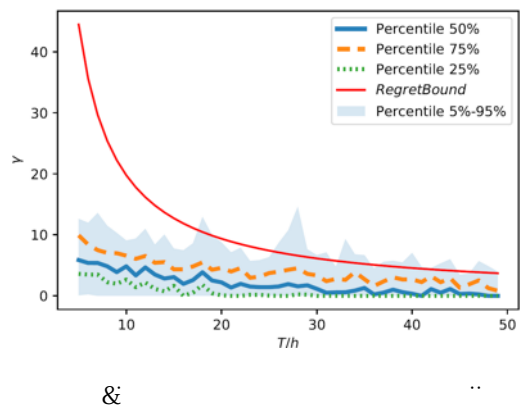
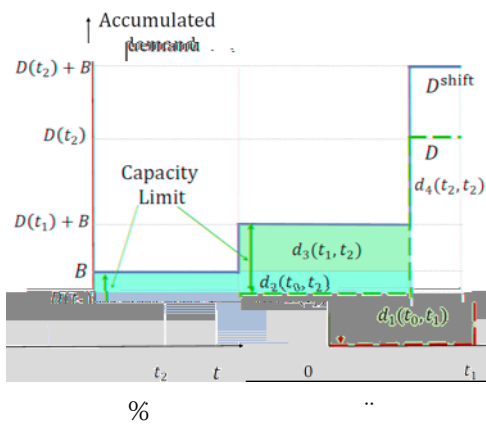



%#Y

00

; AA 9A ; AA

[1] Chi-Kin Chau, Guanglin Zhang, Minghua Chen. “Cost minimizing online algorithms for energy storage management with worst-case guarantee,” IEEE Trans. on Smart Grid, vol. 7, no. 6, pp. 2691 – 2702, 2016.; [2] Jiaman Wu, Zhiqi Wang, Yang Yu, Chenye Wu. “Optimal Storage Control for Dynamic Pricing” , in submission to IEEE PES General Meeting 2020. <https://arxiv.org/abs/1911.06963>; [3] Jiaman Wu, Zhiqi Wang, Chenye Wu, Kui Wang, Yang Yu. “A Data-driven Storage Control Framework for Dynamic Pricing” , in submission to IEEE Transactions on Smart Grid, Initial Submission: Nov. 2019. <http://arxiv.org/abs/1912.01440>.



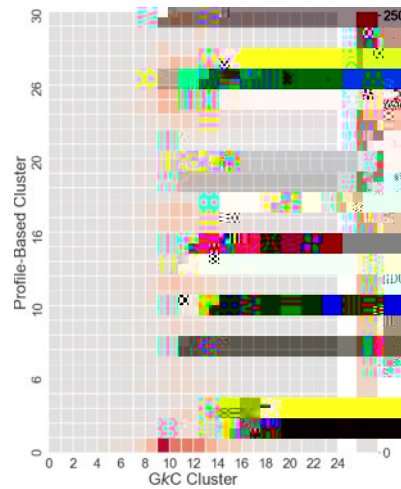
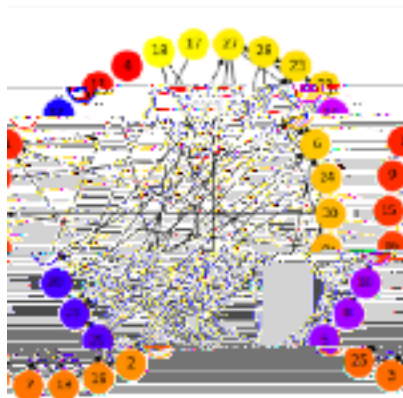

[1] Yang Yu, Guangyi Liu, Wendong Zhu, Fei Wang, et al. Good consumer or bad consumer: Economic information revealed from demand profiles, *IEEE Transactions on Smart Grid*, vol. 9, no. 3, pp. 2347-2358, May 2018; [2] Jingshi Cui, Haoxiang Wang, Chenye Wu, Yang Yu. "Vulnerable Analysis for Data Driven Pricing Schemes", in submission to IEEE PES General Meeting 2020, <https://arxiv.org/abs/1911.07453>, 2019; [3] Jingshi Cui, Haoxiang Wang, Chenye Wu, Yang Yu. "Robust Data-driven Profile-based Pricing Schemes", in submission to *IEEE Transactions on Smart Grid*, Initial Submission: Nov. 2019.



; 1 fJ ØL

$\Omega(m)z$  Ê fa b<sup>9#&~</sup>c[ 'K L Q Uvck /

HUF'Ub`%- %8i UbzDYHjY/ 'G '88%+Q

Ê fa<sup>'#8</sup>b<sup>~</sup>c[ 'K L K

Vla UHW]b[ ZZMcf

c'Vla UHW]b[. i % VHL Ê fa b<sup>9#&~</sup>c[ 'K L @Y/ 'GjZcfX88%Q

Vla UHW]b[ l.9 B iž .....

$n(u,v)$  l fHL VHL ZZMcf cfa bL

c'ZZMcf. i % ZHL ZZMcf Ê fa b<sup>8#</sup>c[ 'K L Z

9 % : : i ZYXjYWj Yf : ZHL

ZHL Ê fa b<sup>8#</sup>c[ 'K L Øi Ubž

Vla UHW]b[ DYHjY/ 'G '88%+Q gW]b[ Q Uvck '88%Q

ZZMcf Vcgga

Vla UHW]b[ ZZMcf Vla UHW]b[

Vla UHW]b[ ZZMcf ..... FUb'8i Ubz< Uce]b[ '< YZH]UbnjN\Ub["

V Z "5 'GW]b[ '5 '[cf]h\ a 'Zcf'K Y[ \hXZi: UMcfg]b'; YbYFU'

$\Omega(mn)/$  ZZMcf ; fUd\gž]b]g Va ]ggcb"

h.zactehjng

f-factor

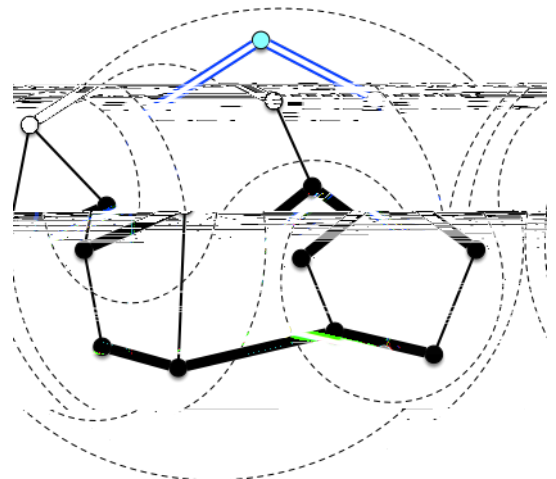
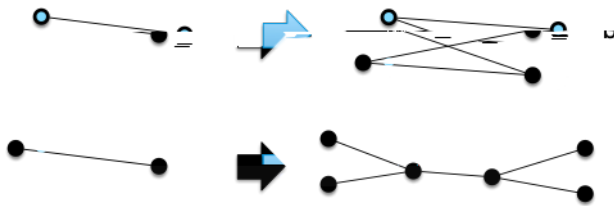

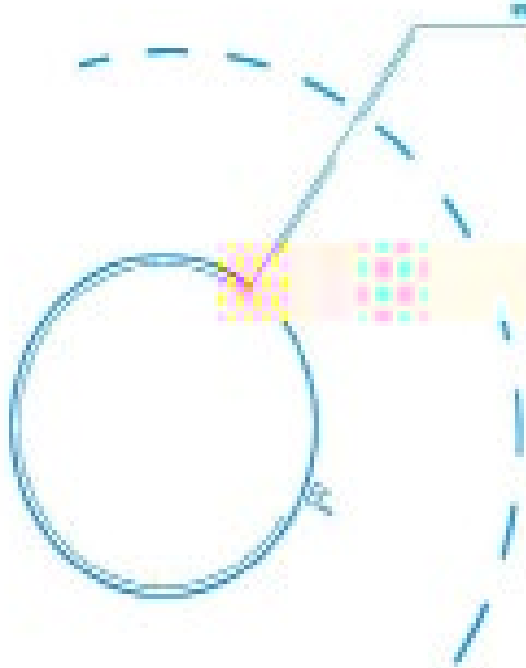
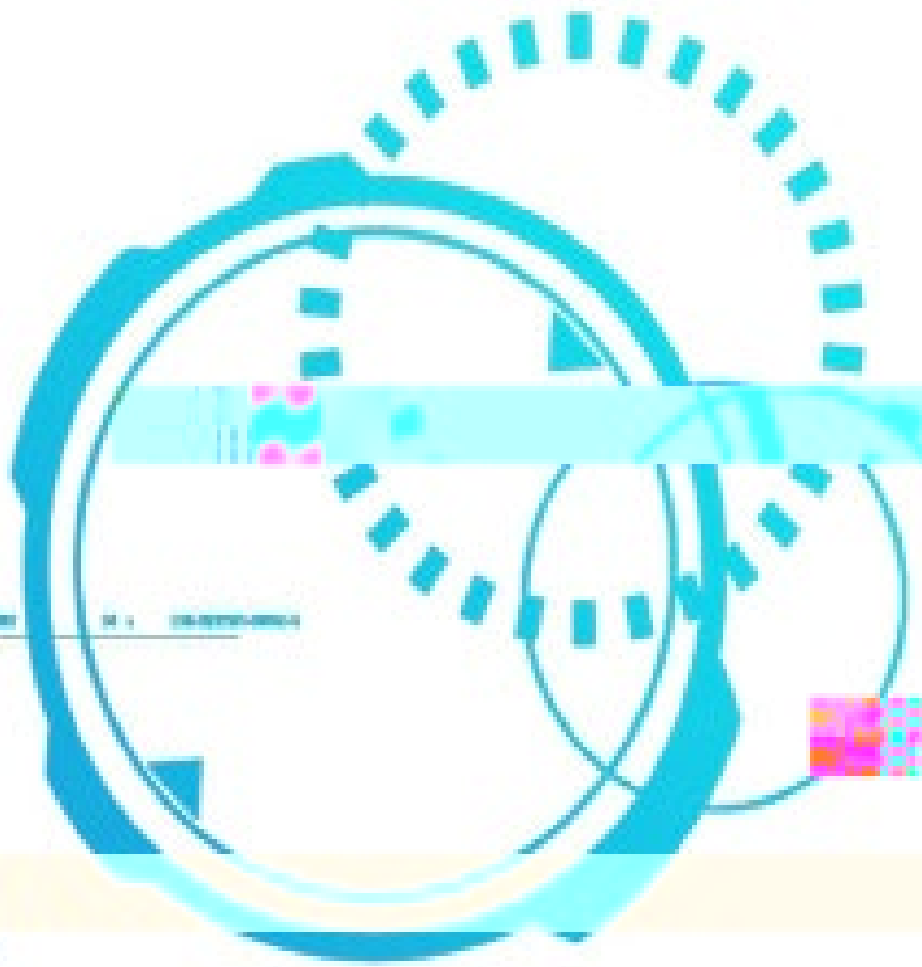
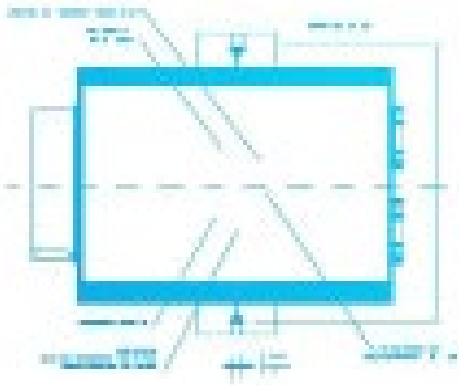

+ + + + + + + + + +

量

子

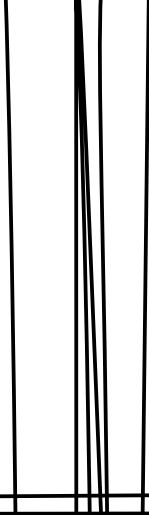

8@7N 8i Ub!@\_!b!7]fUMNc`Yf

%\$

8@7N

..... K '7\Ub[ž7'@žMP 'Ki žB '}>]Ub[ž  
 G'N\Ub[žM 'Di žLM7\Ub[ž@A '8i Ub"'"@cb[!X]gUbW  
 YbLb[ 'Ya YbhVYk Yyb Ua i 'hd'Yl YXeI Ubi a 'a Ya cfmLbXU  
 h'YWa 'd\cfc b' žD\ng"FY "L"

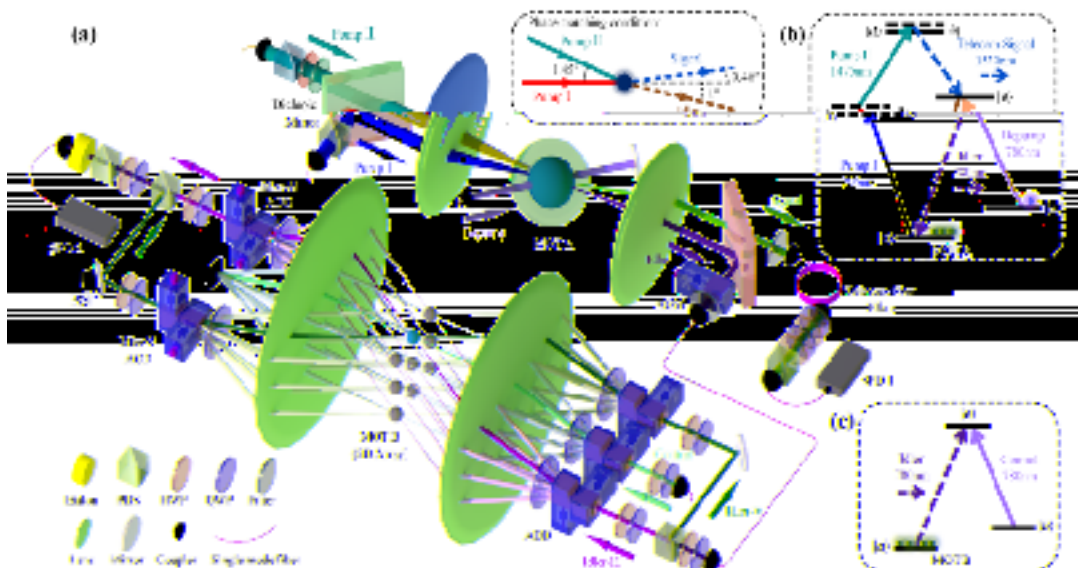

$f_{XY}^{\text{int}}$        $G_{\text{Wa}} \text{ } \mathcal{X}_h \text{ } j \text{ } c_b \text{ } B \text{ } Y \text{ } a \text{ } U_{bb}$        $g_{\text{dUFUVYgUH}}$   
 $; < N$       &

Mti 'N\ci žE ]'N\UcžL ]Uc 'M UbžUbXL ]cb[ Žb[ 'AU" 8 YW]b[ 'a i 'hdUfhY'YbHb[ 'Ya Ybhgfi W fY  
 k ]h 'a ]b]a U'fYgci fWg žbd^E i Ubli a 'bZcfa U]cb"

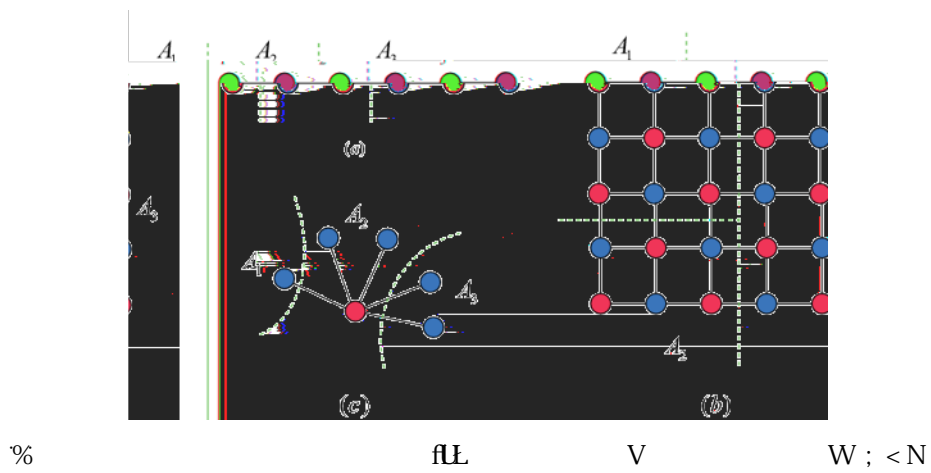

K ; <N

K  
; <N

K ; <N  
; <N

B K B K ; <N

ei lf]lei lf]h

@]bn\]'@bžN\Uc\i ]'K Y]"

"Hyg]b[ 'h\Y Gfi Wf fYcZA i 'hdUfh]hY'9bHb[ 'Ya Ybhk ]h'

< UFXngBcb`cW]mžUFL.j.&SS%S&%( ' "

N\Uc\i ]'K Y]ž@]bn\]'

@]b""5bU`nh]WGYa ]!Xy ]W]bXYdYbXYbh'9bHb[ 'Ya Ybh

E i Ubh]Z]WWh]cb`Zcf`6]dUfh]hY'E i Ubhi a `GhUhYg'ž

UFL.j.%S "S)' \$'j' "



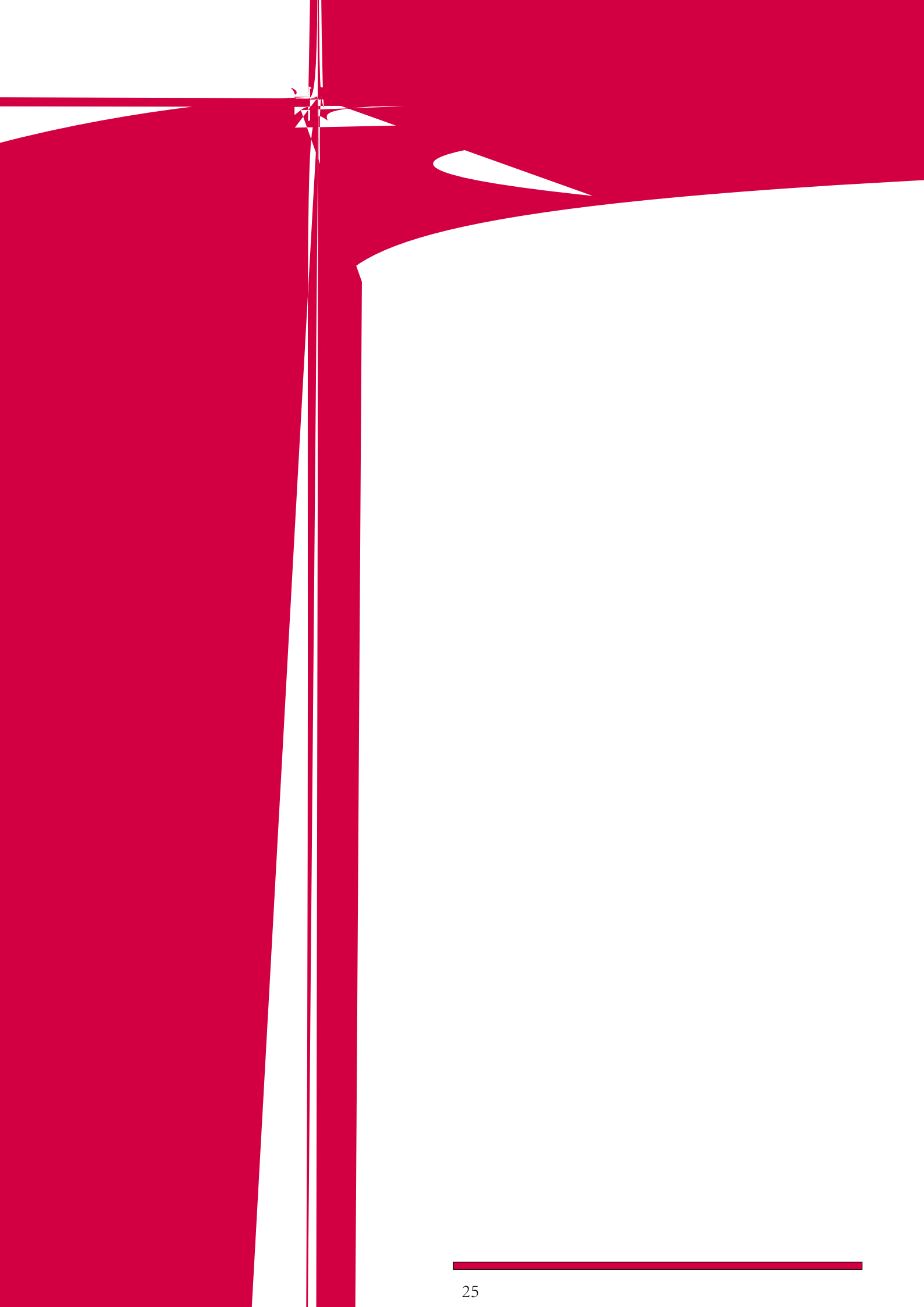

BCCB ; <N

@; C

BCCB ; <N

. K "K Ub[žM'K i žM'A ŹK "'7Už@"

< i žL "Ai žM'Li žN]!>Y7\Ybž< "K Ub[žM'D"Gcb[ž< "M Ubž

7"!@"Nci ž@!A "8i Ub/ '@"G b" < YgybVf[!]a ]hXgb[ 'Y

a cXYei Ubi a 'a Yfc`c[ m]b'U'g dYVwbXl V]b[ 'VfW]hž

BUi fY7ca a i b]W]cbg"

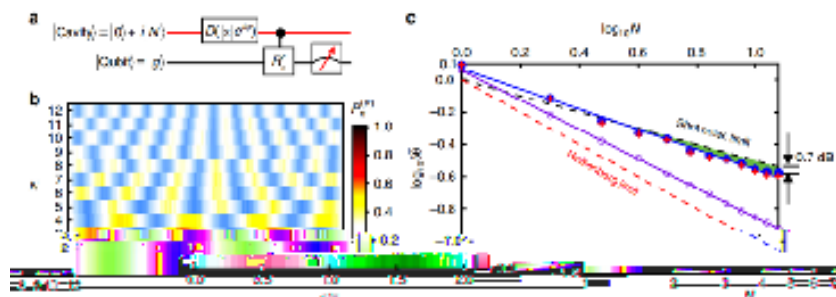
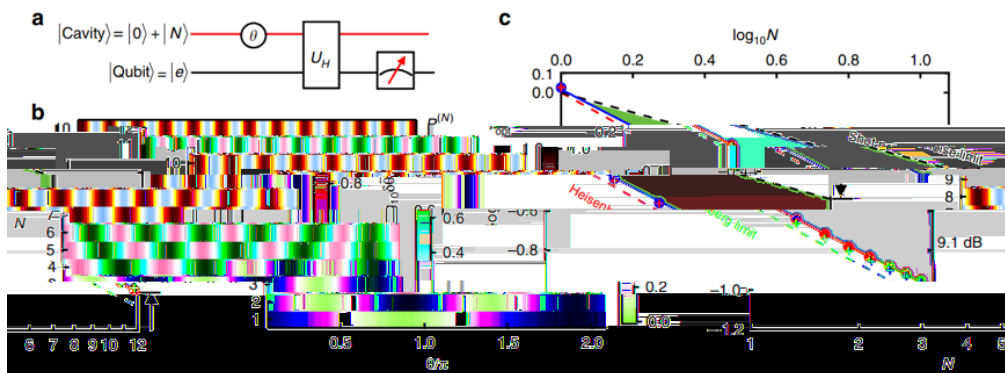
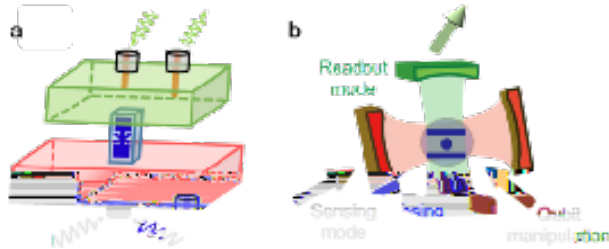



S %

S %

% &

5D=

8E7%

f5DŁ

? i Ub'N\Ub[ž>UbYH\ca dgbž

L ]Ub[ 'N\Ub[žMUb[ WUc'G.YbžMc'@ žG.i U]b|'N\Ub[ž

>Uř b'AŮJ `Uhc'JYfUžA ]Y; i / ? ]kUb? ja ""AcX'U'

ei Ubi a `Wa di Hhcb' ]b'U'fUddYX ]cb' gphYa ~žB Uhi fY

7ca a i b]W]cbg'

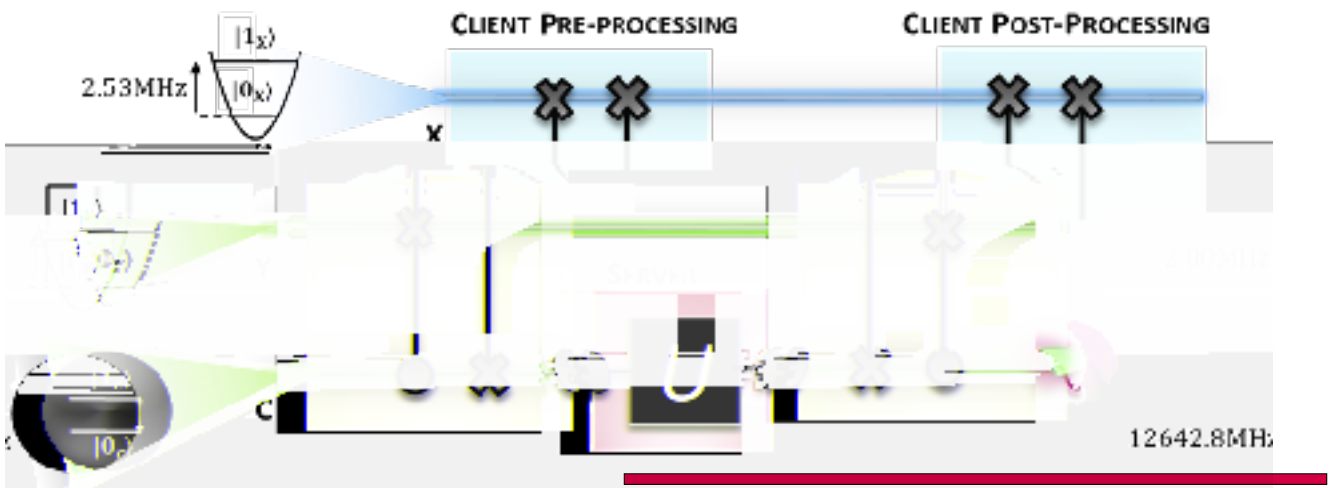

; < N

Mci 'N\ci " 9bhLb[ 'Ya YbhiXfMjcb'

i bXf'W\YfYbhc]gY'; fYbVf[Yf!< cfbYNY]'b[Yf!`\_Y

gUhg D\ng"FY "5"

Zcfa Ujcb

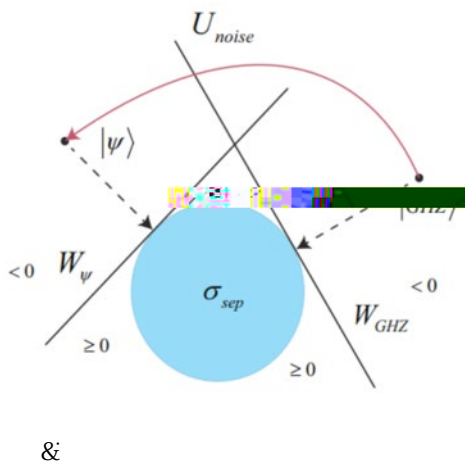

L]Uc'M UbzE ]'N\Ucz8 Uj ]XY

; ]fc'Ua ]zUbXL]cb[ Zfb[ 'A U' E i Ubli a '7c\YfYbWUbX

=bf]bgVfUbXca bYgg z5Xj UbWXE i Ubli a HYWbc`c[m

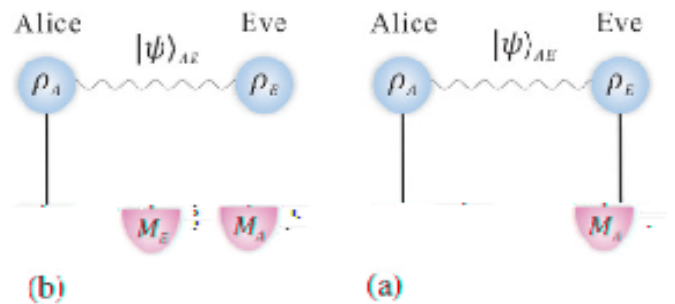

Ға ҮсZÜ[\ \h

Ғbl

. Q\>]Ub[žGfi ]@ žUbX8cb[!@]b[

8 Yb["~J i `bYUW]hrcZA UW]bY@YUfb]b[ D\UgycZA Uhmž

UFLj. %%%% () ' "

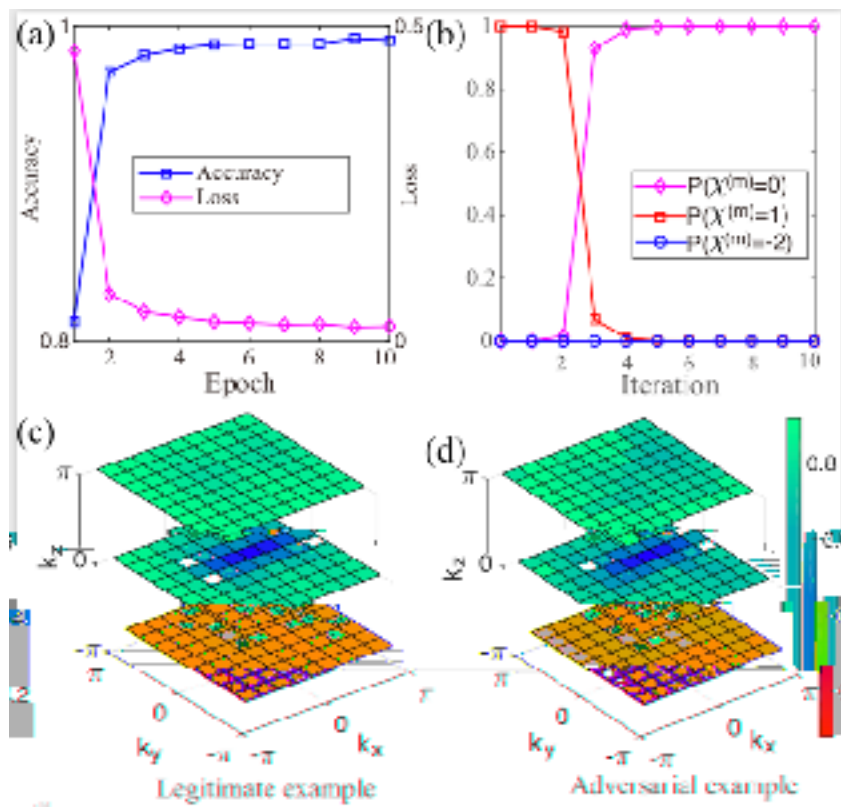

GnY YXm

&S%

--" 1

.:Gfi ]'@ ž@ !A ]b[ '8 i UbžUbX8 cb[ !

@]b[ '8 Yb[ ""Ei Ubi a '5Xj YfgUf]'`A UW]bY@Ufb]b[ "žUFL j.:

&S%SSS' S'

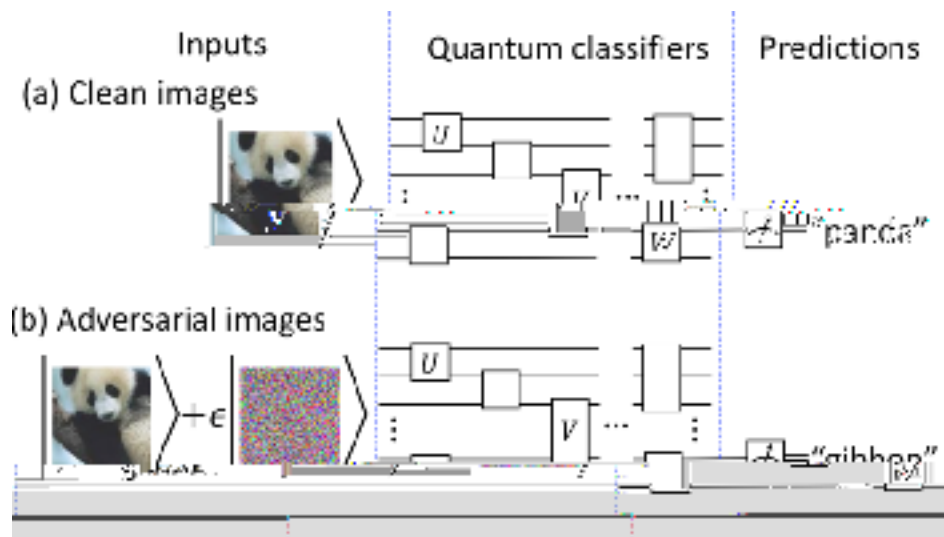



Edited by Kailin Li

Reviewed by Xiamin Lv

